

AUFSPANN - KOMPONENTEN CLAMPING - COMPONENTS



B-S-D Spanntechnik GmbH
A-3385 Markersdorf Sportplatzstraße 31
Tel.: +43 (0)2749/72870-0 Fax: DW 70
Email: office@bsdustria.com
www.Die-Spanntechniker.at



Angle plate A

Aufspann - Winkel A

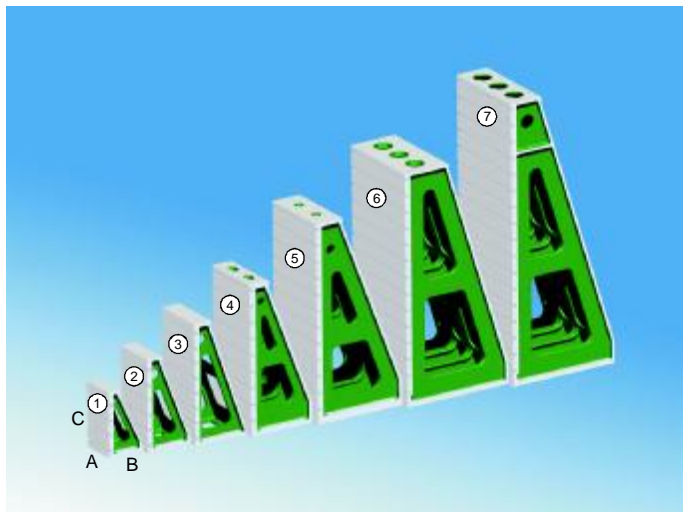

MATERIAL EN-GJL-300Á ÇÖÄĤ					
	DIMENSION			T-SLOTS	WEIGHT
	ÇĖT ÖÜŪŦÖ			ÄĖŦ	ÄÖŪ ÇŦV
	A	B	C	Ÿ ÇŦVÄÖÜÇŦÖ	kg
A1	400	400	700	18H8 / 22H8	200
A2	500	500	1000	18H8 / 22H8	350
A3	600	600	1300	18H8 / 22H8	500
A4	700	720	1620	22H8 / 28H8	1000
A5	800	1000	2150	22H8 / 28H8	1700
A6	1000	1200	2500	22H8 / 28H8	2400
A7	1000	1200	3000	22H8 / 28H8	2800

Clamping cube

Aufspann - Tisch B

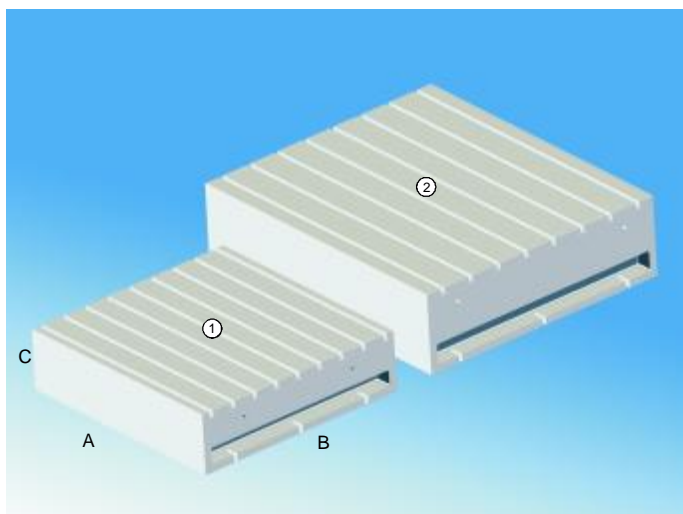

MATERIAL EN-GJL-300Á ÇÖÄĤ					
	DIMENSION			T-SLOTS	WEIGHT
	ÇĖT ÖÜŪŦÖ			ÄĖŦ	ÄÖŪ ÇŦV
	A	B	C	Ÿ ÇŦVÄÖÜÇŦÖ	kg
B1	1150	1100	300	18H8 / 22H8 / 28H8	1000
B2	1500	1300	400	18H8 / 22H8 / 28H8	1900
B3	1150	1100	500	18H8 / 22H8 / 28H8	1390
B4	1500	1300	400	ŦÜŦÖÄÖÇŦÄŦŦ	1380

Clamping cube C

Aufspann - Würfel C

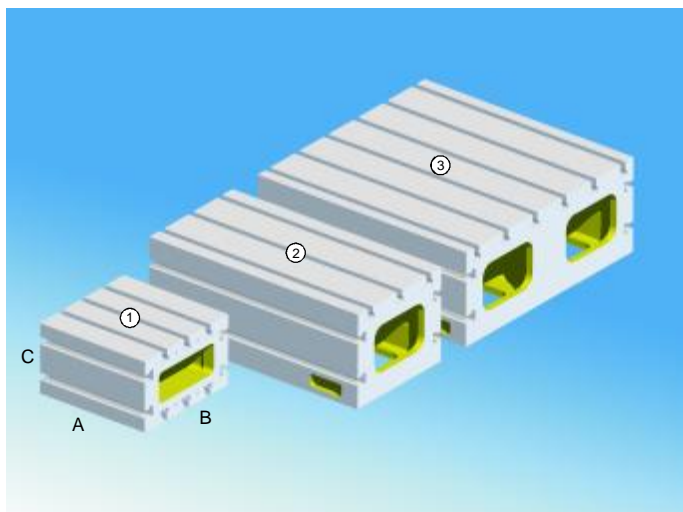

MATERIAL EN-GJL-300Á ÇÖÄĤ					
	DIMENSION			T-SLOTS	WEIGHT
	ÇĖT ÖÜŪŦÖ			ÄĖŦ	ÄÖŪ ÇŦV
	A	B	C	Ÿ ÇŦVÄÖÜÇŦÖ	kg
C1	500	500	300	18H8 / 22H8 / 28H8	340
C1 A	500	700	360	18H8 / 22H8 / 28H8	450
C2	1000	500	400	18H8 / 22H8 / 28H8	450
C3	1000	1000	400	18H8 / 22H8 / 28H8	800
C4	1000	500	500	18H8 / 22H8 / 28H8	635

Clamping cube D

Aufspann - Winkel D doppelseitig

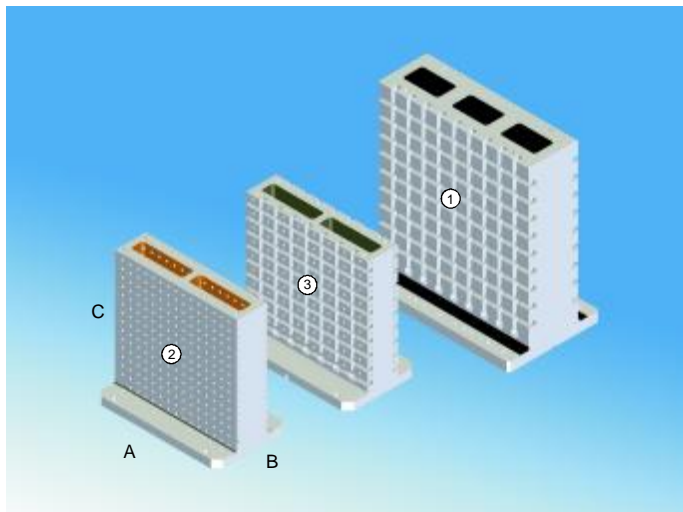

MATERIAL EN-GJL-300 (GG 30)					
	DIMENSION			T-SLOTS	WEIGHT
	ABMESSUNG			T-NUT	GEWICHT
	A	B	C	WIDTH / BREITE	kg
D1	1000	320/600	1100	18H8 / 22H8	1200
D2	800	200/460	800	M16	650
D3	800	200/460	800	18H8 + M16	550

Clamping cube E

Aufspann - Kastenwinkel E doppelseitig

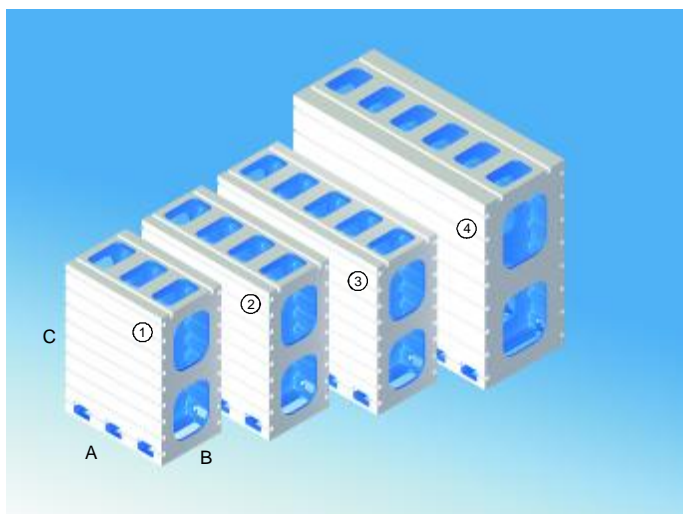

MATERIAL EN-GJL-300 (GG 30)					
	DIMENSION			T-SLOTS	WEIGHT
	ABMESSUNG			T-NUT	GEWICHT
	A	B	C	WIDTH / BREITE	kg
E1	1200	750	1600	22H8 / 28H8	1600
E2	1600	750	1600	22H8 / 28H8	2100
E3	2000	750	1600	22H8 / 28H8	2600
E4	2400	1000	2000	22H8 / 28H8	4100

Angle plate F

Aufspann - Winkel F

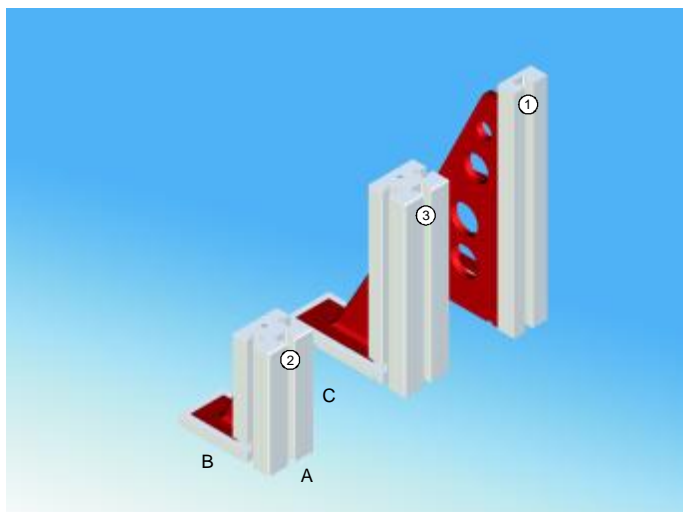

MATERIAL EN-GJL-300 (GG 30)					
	DIMENSION			T-SLOTS	WEIGHT
	ABMESSUNG			T-NUT	GEWICHT
	A	B	C	WIDTH / BREITE	kg
F1	110	400	700	18H8 / 22H8	55
F2	150	300	350	18H8 / 22H8	45
F3	150	400	550	18H8 / 22H8	75

Angle plate G

Aufspann - Platte G

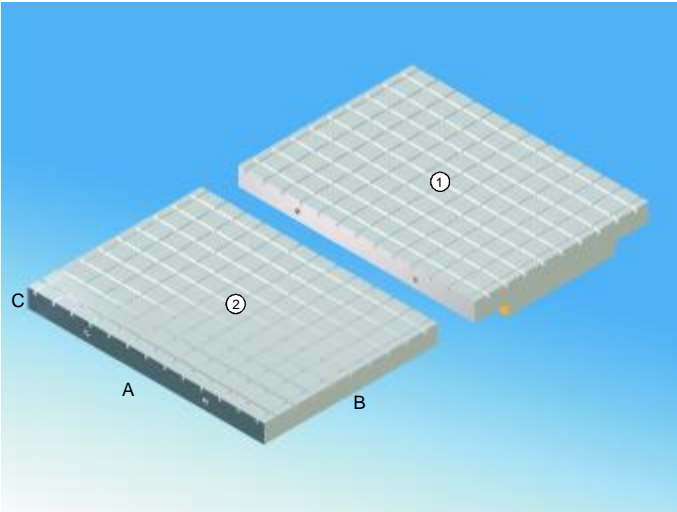

MATERIAL EN-GJL-300 (GG 30)					
	DIMENSION			T-SLOTS	WEIGHT
	ABMESSUNG			T-NUT	GEWICHT
	A	B	C	WIDTH / BREITE	kg
G1	3200	2350	400	22H8 / 28H8	7000
G2	3200	2350	250	22H8 / 28H8	5800

Clamping cube H

Aufspann - Würfel H

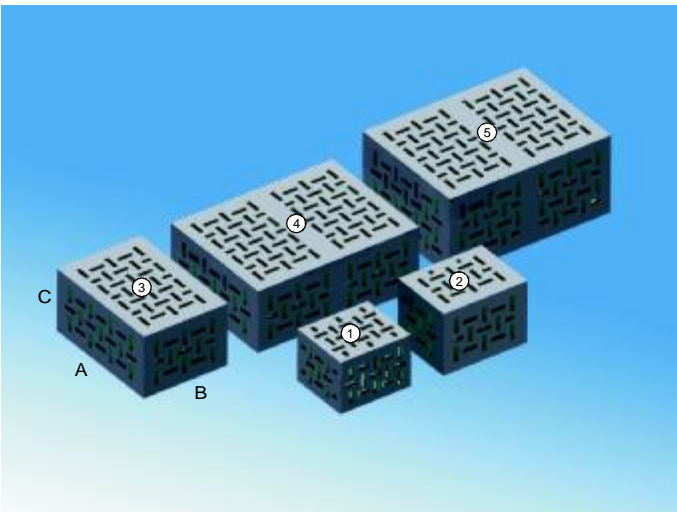

MATERIAL EN-GJL-300 (GG 30)					
	DIMENSION			T-SLOTS	WEIGHT
	ABMESSUNG			T-NUT	GEWICHT
	A	B	C	WIDTH / BREITE	kg
H1	600	700	500	38	330
H2	630	830	600	38	740
H3	1200	830	600	38	1200
H4	1200	1600	600	38	2150
H5	1200	1600	750	38	2400

Angle plate I

Aufspann - Platte I

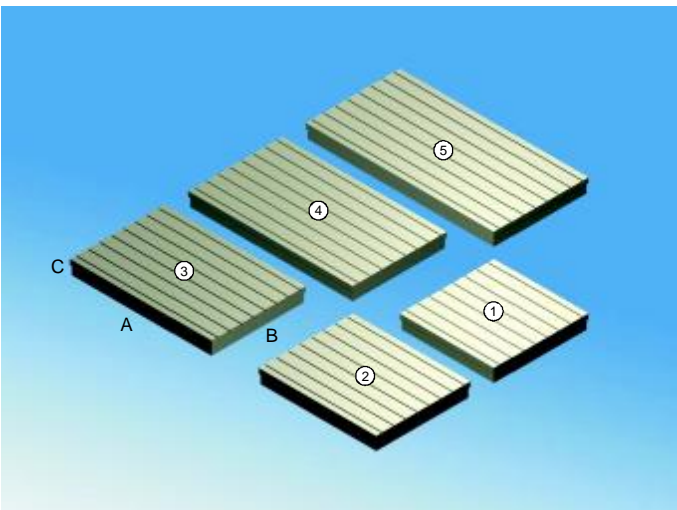

MATERIAL EN-GJL-300 (GG 30)					
	DIMENSION			T-SLOTS	WEIGHT
	ABMESSUNG			T-NUT	GEWICHT
	A	B	C	WIDTH / BREITE	kg
I1	2000	2000	300	22H8 / 28H8 / 36H8	3150
I2	2500	2000	300	22H8 / 28H8 / 36H8	3900
I3	3000	2000	300	22H8 / 28H8 / 36H8	4650
I4	3500	2000	300	22H8 / 28H8 / 36H8	5400
I5	4000	2000	300	22H8 / 28H8 / 36H8	6150

Angle plate J

Aufspann - Winkel J

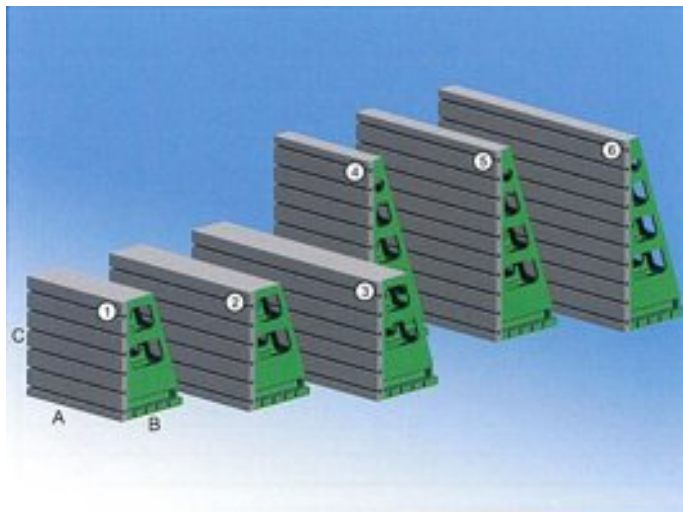

MATERIAL EN-GJL-300 (GG 30)					
	DIMENSION			T-SLOTS	WEIGHT
	ABMESSUNG			T-NUT	GEWICHT
	A	B	C	WIDTH / BREITE	kg
J1	1350	870	1250	22H8 / 28H8	2050
J2	2000	870	1250	22H8 / 28H8	2930
J3	2650	870	1250	22H8 / 28H8	3820
J4	1350	870	2000	22H8 / 28H8	2810
J5	2000	870	2000	22H8 / 28H8	4050
J6	2650	870	2000	22H8 / 28H8	5300

Marking table K

Anreiß - Platte K

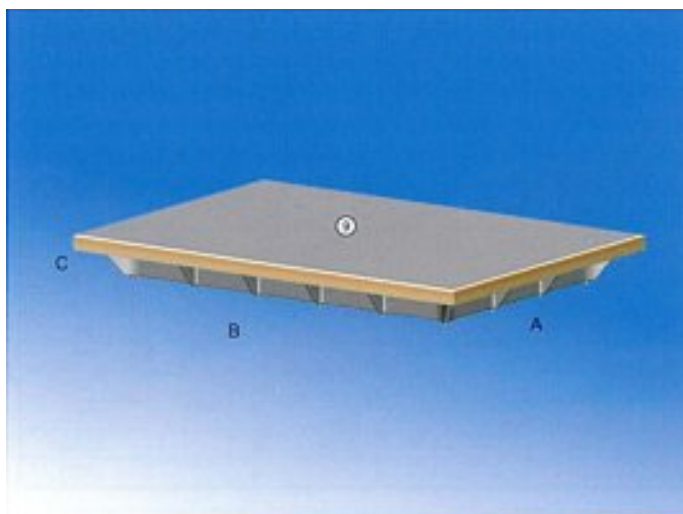

MATERIAL EN-GJL-300 (GG 30)					
	DIMENSION			T-SLOTS	WEIGHT
	ABMESSUNG			T-NUT	GEWICHT
	A	B	C	WIDTH / BREITE	kg
K1	1500	1500	300	-	1530
K2	1500	2000	300	-	2010
K3	1500	2500	300	-	2560
K7	2000	2000	300	-	2760
K8	2000	2500	300	-	3490
K9	2000	3000	300	-	4210

T-slot bar L

T-Nutenschiene L



MATERIAL EN-GJL-300 (GG 30)					
	DIMENSION			T-SLOTS	WEIGHT
	ABMESSUNG			T-NUT	GEWICHT
	A	B	C	WIDTH / BREITE	kg
L	350	5000	205	28H8 / 36H8 / 42H8	1350